

BTE

Bluetooth™ Protocol Software Suite for embedded systems.

WIDCOMM's Protocol Software Suite for embedded systems (BTE) is an extremely complete communications software solution of source code and documentation for adding *Bluetooth™* wireless radio technology to any embedded systems. BTE enables OEM embedded application developers to quickly and easily port onto their desired platform of choice, any processor and any OS speeding up application development. The HOST stack component of BTE is fully compliant with the Bluetooth v1.1 Protocol Specification and leverages BQB conformance testing into your product. BTE comes complete with all of the standard *Bluetooth* profiles and has been architected in a modular way which makes it configurable, extremely portable, robust, reliable, and maintainable across any embedded platform or OS. BTE has been developed and validated with an ARM™ processor, but is easily ported to other target processor platforms. BTE can be easily adapted to all Bluetooth applications, ranging from low-end, cost driven products to high-end devices with extensive feature sets.

BTE Bluetooth Protocol Architecture

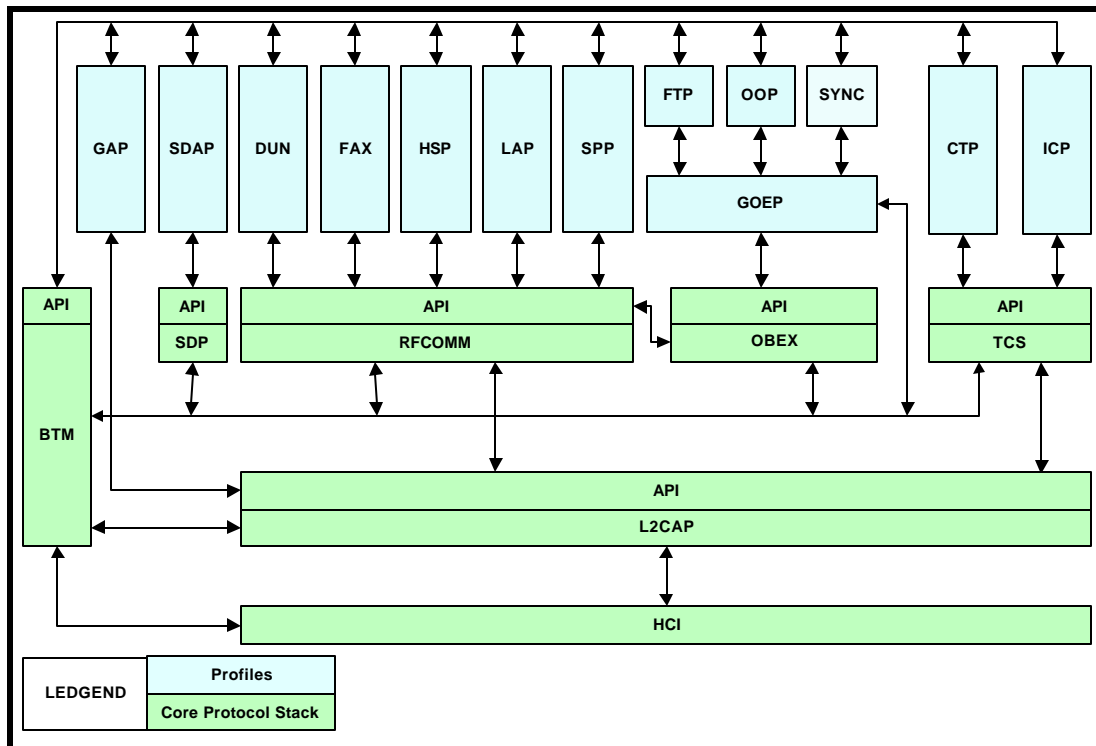

Distinguishing Features

Code Portability and Platform Independence

BTE is extremely portable and reusable over a wide array of platform. BTE comes complete with source code for the *Bluetooth* Protocol Stack (L2CAP, SDP, RFCOMM, OBEX, TCS, BTM) and all the standard Bluetooth Profiles. BTE also includes GKI a mini-OS and sample HCI chipset drivers, example Bluetooth applications and thorough documentation describing each module provided. Profiles come complete with both API documentation and design usage documents giving detailed examples of how to use Bluetooth profiles to implement applications.

Simple OS Porting and Reduced Development Cost

BTE includes a generalized operating system or Generic Kernel Interface (GKI) package that can be easily configured to run either as a complete operating system or as a layer of software that resides between applications and virtually any real time operating system. GKI is designed so that any applications that use the GKI's function calls can be ported on top of other operation system without any changes (the OS is accessed through an OS abstraction layer). GKI can also be configured to serve as a complete operating system and has been implemented to run on top of a number of different operating systems.

Maximum Design Flexibility and Scalability

BTE provides a number of important features needed for embedded development.

- Flexible buffer management improving performance and resource usage.
- Small configurable footprint making BTE efficient for embedded systems.
- Support for Timer Management and low-power modes of operation.
- Data and Voice support.
- HCI transport support.
- Non-Volatile Memory support.
- Detailed Porting Guide for easy porting to multiple RTOS platforms.
- Sample Applications for QuickConnect boards.
- ARM evaluation compiler (valid for 35 days).

Development Platform Accelerates Time to Market

BTE comes complete with two QuickConnect development boards allowing embedded developers to perform various wireless data and audio communications using Bluetooth technology, This gives users a head-start in Bluetooth applications development. QuickConnect developer boards have an ARM7 based micro-controller, complete memory subsystem, 2 serial ports, power circuits, audio codec and a Bluetooth radio module which supports serial/UART HCI. The CD-ROM provided with BTE contains all the software and documentation needed to connect to a PC via an RS232 cable for software download allowing you to execute your own applications without custom hardware. The board also has jumpers for re-directing the RS-232 signals going to the provided Bluetooth module to an external Bluetooth serial adapter.

Full Source code access

BTE is delivered with ANSI-C source code, allowing developers full access to the protocol stack and profiles. Access to the source code gives developers the technology insight they need to create leading edge products. While no alteration of the protocol stack is required, understanding source code enables developers to write more efficient applications, add innovative features, and fine tune the Bluetooth HOST stack and Profiles to their special requirements. A comprehensive set of API's gives access to the HOST stack so that additional routines or new profiles can be added easily.

Powerful Companion Test Tool

BTE comes with built-in features which work with the optional embedded Protocol Stack Tester (PST), a powerful test scripting engine with extensive capabilities for real-time simulation and control that provides developers unparalleled visibility to all layers of the core protocol stack. Hundreds of test script files have been created which cover comprehensive operational testing at HCI, upper stack and profiles levels. PST provides users with simple integration, powerful analyzer diagnostics capabilities and a flexible debug environment.

Interoperability and Uncompromising Quality

A leader in both conformance testing and interoperability, WIDCOMM was the first company to receive a BQB product listing, and the first 1.0B qualified Bluetooth protocol stack. A very major participate at every Bluetooth unplugfest, WIDCOMM is a proven leader in demonstrating

Bluetooth interoperability between PDAs, PCs, mobile phones and network access points. BTE customers leverage our BQB conformance and expertise into their end product application certification.

Support and Training

Widcomm provides an array of professional services from product training to extensive technical support.

BTE Directory Structure when Installed

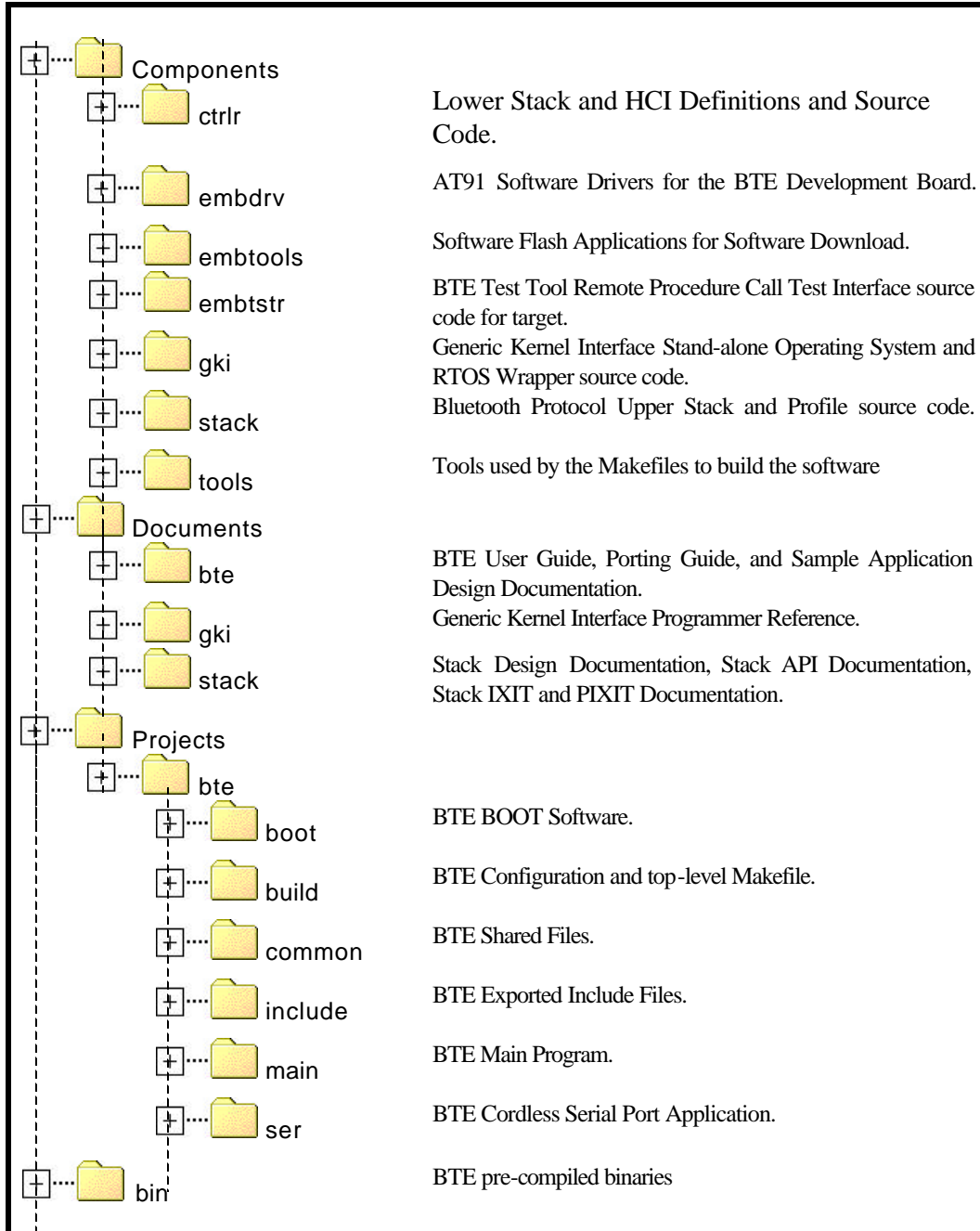

Package Description:

- Source code libraries in ANSI-C for WIDCOMM's implementation of the *Bluetooth* v1.1 specification core upper protocol stack layers.

Logical Link Control and Adaptation Protocol (L2CAP)	RFCOMM
Telephony Control Protocol (TCS)	Service Discovery Protocol (SDP)
Object Exchange Profile (OBEX)	Bluetooth Manager (BTM)

- Source code libraries in ANSI-C for Bluetooth Spec 1.1 compliant profiles.

Generic Access Profile	Serial Port Profile
------------------------	---------------------

- Source code libraries in ANSI-C for Bluetooth Spec 1.1 compliant *Optional Profiles*.

<i>Service Discovery App Profile</i>	<i>Headset Profile</i>
<i>Fax Profile</i>	<i>Generic Object Exchange Profile</i>
<i>Object Push Profile</i>	<i>File Transfer Profile</i>
<i>Dial-up Network Profile</i>	<i>LAN Access Profile</i>
<i>Intercom Profile</i>	<i>Cordless Telephony Profile</i>

- Documentation and Source code for Generic Kernel Interface, a mini-OS for embedded systems.
- Source code for standard HCI drivers for selected chipsets.
- An extensive OS porting guide for embedded systems.
- Extensive documentation that exposes and details Bluetooth wireless technology application programming interface (API). APIs allow custom Bluetooth enabled applications to be created.
- Source code for the remote proxy required to communicate with the Protocol Stack Tester.
- Comprehensive BTE User's Manual and Release Notes.
- Sample applications programs demonstrating Bluetooth connectivity "right out of the box".
- Delivered with two (2) QuickConnect embedded reference boards with data and voice/audio capability providing users a convenient Bluetooth technology development platform.
- Effective and responsive application development technical support.

For more information contact WIDCOMM at:

Widcomm Inc.
9645 Scranton Road
Suite 205
San Diego, CA 92121
858-453-8400 (phone)
858-453-5735 (fax)
www.widcomm.com
info@widcomm.com



QuickConnect BTE Reference Set